

SV51

2-Way Normally Closed Diaphragm Isolation Valves

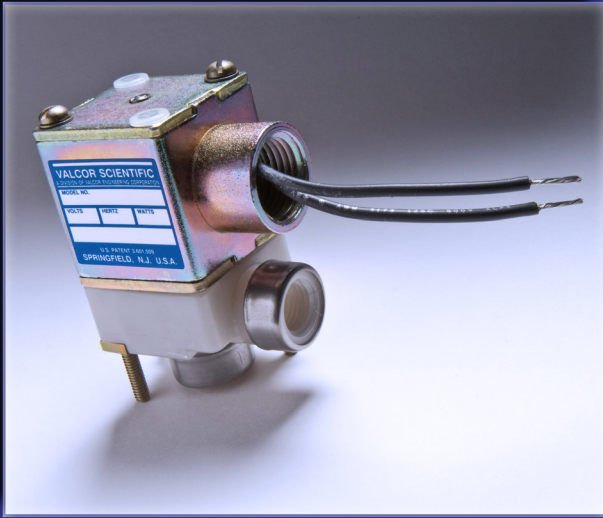

Valcor Engineering Corporation



DESCRIPTION

The SV51 series 2-way normally closed diaphragm isolation valves provide high purity isolation of the media from the valve mechanism by excluding all metal components from the fluid path. Employing polypropylene bodies and elastomeric diaphragms allows these valves to handle corrosive or high purity liquids and gases without breaking down or contaminating the purity of the media. For ultra high purity or aggressive media, an all PTFE construction is available. They are direct acting, do not require system pressure to operate, and can control pressure and vacuum. A novel right angle flow path allows for higher flow rates from each orifice size.

APPLICATION

The SV51 series are ideal for applications where the media cannot contact metallic components. Cost-effective polypropylene/elastomer construction is suitable for most applications, and an all PTFE construction is available for high purity or aggressive media. Applications include: analytical and medical instruments and equipment, hydrogen peroxide and ethylene oxide sterilizers, water purification systems, detergent and cleaning chemical dispensing, food and beverage packaging, and printing inks, dyes, and colorants.

FEATURES

- 130 PSIG maximum pressure
- 24" Hg vacuum
- Cvs from 0.1 to 1.9 available
- Right Angle flow path
- 115/60 VAC and 24 VDC 10 watt coils rated for continuous duty
- 1/4" NPT ports
- Mountable in any orientation
- Fully customizable for your application

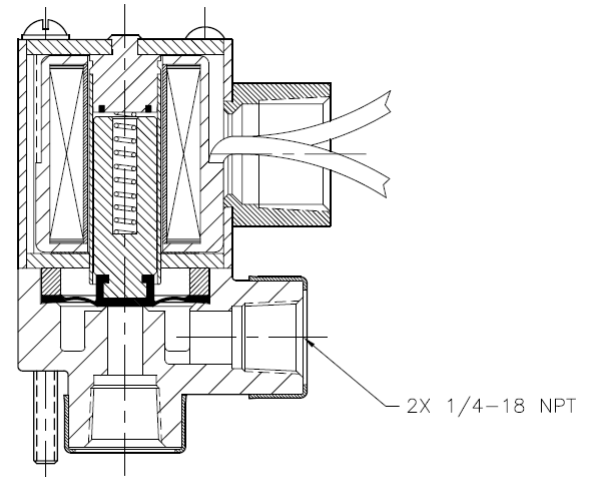

INLET

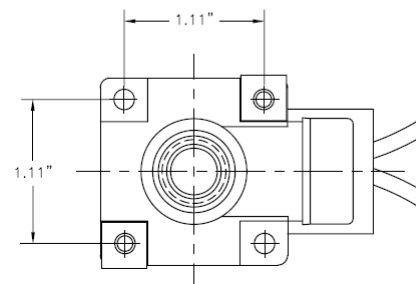
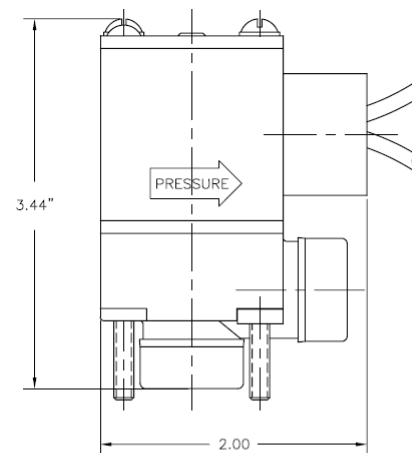

Custom designs are our specialty. Contact us today to see how we can help on your next project.

Valcor Engineering Corporation
2 Lawrence Road | Springfield, NJ 07081
(973) 467-8400 | scientific@valcor.com
www.valcor.com

SV51

2-Way Normally Closed Diaphragm Isolation Valves



Valcor Engineering Corporation

Valve Parts in Contact With Fluid

Body	PTFE, Polypropylene
Diaphragm	PTFE, FKM, EPDM

Other Parts

Body Seal	Buna-N or Neoprene
Plunger Tube	303 SS
Plunger	430F SS
Shading Coil	Silver
Plunger Stop	430F SS
Spring	303 SS

Electrical

Standard Voltages	115/60 AC & 24/VDC. Consult factory for other voltages (available).
Wattage	10 watts for 115/60 Hz and 24 VDC constructions
Standard Coil Housing	Coils have class B insulation and 18" leads. General purpose with 1/2" NPT conduit. Explosion proof and grommeted pigtails housing is also available. Consult factory. Replace 1st "C" in part number with "G" for grommeted pigtails. Example: SV51G19G24-1 for grommeted pigtail solenoid housing

Part Number Configurator

Example Part Number: SV51C19G24-3



Numbers 1 thru 4		5		6-7		8		9		10		11		12	
Series	Operating Mode	Housing		Applicable Voltage		Body Material		Diaphragm Material		Pipe Connection (NPT)		Orifice Size (in.)		Option	
SV51	Normally Closed	C	Conduit	19	115/60 Hz	G	Polypropylene	2	FKM	4	1/4"	1	1/16	V	Vacuum
		G	Grommet	56	24 VDC	T	PTFE*	3	PTFE	6*	3/8"	3	1/8		
		P	Grommeted Pigtails					8	EPDM			5*	3/16		
												6	1/4		
												7*	5/16		
												8	3/8		

*Valve with 3/8" NPT pipe connection is only available with orifice size 1/4" or larger in polypropylene body.

*Contact factory for valve body availability.

*PTFE body available as a special order. Contact factory for availability.

Specifications for Polypropylene Bodies and FKM Diaphragm

Port Size (ins.) (NPT)	Orifice Size (ins.)	C _v	Minimum Operating Pressure (PSIG)	Max. Operating Pressure (PSIG)		Vacuum at Inlet** in. Hg	Voltage	Model Number*
				Gas	Liquid			
1/4	1/16	0.10	5	130	125		115/60Hz	SV51C19G24-1
1/4	1/16	0.10	5	130	125		24 VDC	SV51C56G24-1
1/4	1/16	0.10				26	115/60Hz	SV51C19G24-1V
1/4	1/16	0.10				26	24 VDC	SV51C56G24-1V
1/4	1/8	0.40	2	60	55		115/60Hz	SV51C19G24-3
1/4	1/8	0.40	2	55	50		24 VDC	SV51C56G24-3
1/4	1/8	0.40				26	115/60Hz	SV51C19G24-3V
1/4	1/8	0.40				26	24 VDC	SV51C56G24-3V
1/4	1/4	1.00	0	12	10		115/60Hz	SV51C19G24-6
1/4	1/4	1.00	0	10	9		24 VDC	SV51C56G24-6
1/4	1/4	1.00				24	115/60Hz	SV51C19G24-6V
1/4	1/4	1.00				24	24 VDC	SV51C56G24-6V
1/4	3/8	1.90	0	6	5		115/60Hz	SV51C19G24-8
1/4	3/8	1.90	0	5	4		24 VDC	SV51C56G24-8
1/4	3/8	1.90				24	115/60Hz	SV51C19G24-8V
1/4	3/8	1.90				20	24 VDC	SV51C56G24-8V
3/8	1/4	1.00	0	12	10		115/60Hz	SV51C19G26-6
3/8	1/4	1.00	0	10	9		24 VDC	SV51C56G26-6
3/8	1/4	1.00				24	115/60Hz	SV51C19G26-6V
3/8	1/4	1.00				20	24 VDC	SV51C56G26-6V
3/8	3/8	1.90	0	6	5		115/60Hz	SV51C19G26-8
3/8	3/8	1.90	0	5	4		24 VDC	SV51C56G26-8
3/8	3/8	1.90				24	115/60Hz	SV51C19G26-8V
3/8	3/8	1.90				20	24 VDC	SV51C56G26-8V

*Part numbers shown are for polypropylene bodies and FKM diaphragms. For other materials of construction, please use part number configurator.

**Vacuum at inlet, outlet at ATM.