

V3400

2-Way Direct Acting Solenoid Valve



Valcor Engineering Corporation



DESCRIPTION

V3400 solenoid valves are specifically designed to meet the critical weight and size limitations in aircraft fuel control systems. They are well-suited for the extreme vibration, temperature, and cycle life requirements found in the most severe operating conditions. The compact size and low weight allows for easy maintenance, saves additional space, and provides for vibration-proof leak-tight pressure boundary seals. These valves are direct acting and do not require system pressure to operate. The V3400 is available in a normally closed or normally open configuration.

APPLICATION

The V3400 is typically used as a fuel shut-off valve on a wide variety of aircraft APUs.

FEATURES

- Maximum Operating Pressure: 600 PSI
- Flow Rate: 200 PPH @ 10 PSIG of MIL-C-7024 Type II
- Leak Rate: Internal is 0.5 cc/hr. External is 0 cc/min at 2200 PSIG
- Temperature: 400°F max.
- Current: 1 Amp, 18 VDC at 70°F, max. 30 VDC
- Electrical Connection: MS 3102A-10SL-4P side-mount standard
- Wetted Materials: Aluminum, CRES 303, 430F, 302, Carbon, Fluorosilicone
- Weight: 0.38 lbs. max.
- Flanged manifold mount
- Self-cleaning wear compensating seat design
- Fully customizable to your application

NORMALLY CLOSED

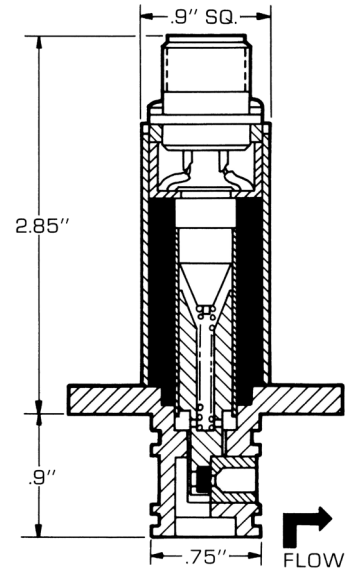

NORMALLY OPEN

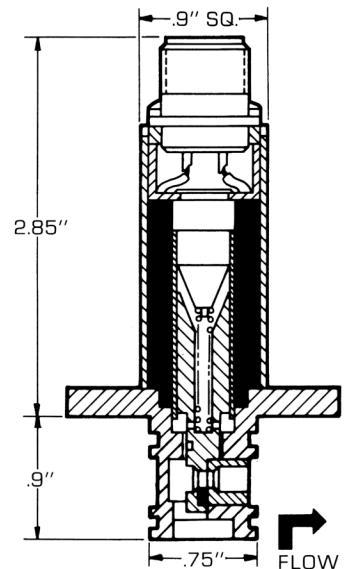

V3400-52-W shown for reference. Flange details shown are typical. Other flange designs, side mounted connectors, etc. are available to meet specific needs.

Custom designs are our specialty. Contact us today to see how we can help on your next project.

Valcor Engineering Corporation
2 Lawrence Road | Springfield, NJ 07081
(973) 467-8400 | aircraft@valcor.com
www.valcor.com

V3400

2-Way Direct Acting Solenoid Valve



Valcor Engineering Corporation

Operating Pressure & Flow Ranges

	Equiv. Sharp Edged Orifice CD =.65	Cv	Operating Pressure (PSIG)		Ambient Temp.	Min. Volts DC
			30 OHM Coil	47 OHM Coil		
Normally Closed Configuration	0.062	0.073	0-1200	0-1000	165°F	18
	0.083	0.135	1-600	0-400	165°F	18
	0.135	0.350	0-90	0-60	165°F	18
Normally Open Configuration	0.062	0.073	1-1200	0-1000	165°F	18
	0.083	0.135	0-800	0-600	165°F	18
	0.135	0.350	0-110	0-90	165°F	18

These ratings are based on using JP4 Aviation Fuel. Other orifice size, both larger and smaller, are available. However, ratings would change accordingly. For higher temperatures, the pressure rating must be reduced. The following table approximates the derating required.

Temperature	Derating Factor
250°F	0.71
350°F	0.62

Electrical Data

Voltage	18 to 32 VDC
Current	Approximately 0.8 amps at 24 VDC. (Depends on application, cooling effect of fluid, etc.)
Electrical Connector	MS 3102A-10SL-4P is standard. Other types are available. Consult factory.

Leakage

External	0 cc/min. at 2200 PSIG
Internal	Liquid Service: 0.5 cc/hr. Gas Service: 15 cc/min.

Custom designs are our specialty. Contact us today to see how we can help on your next project.

Valcor Engineering Corporation
2 Lawrence Road | Springfield, NJ 07081
(973) 467-8400 | aircraft@valcor.com
www.valcor.com