

SV97

2-way Direct Acting, Normally Closed
Cryogenic Solenoid Valve

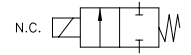

Valcor Cryogenic Series



DESCRIPTION

The SV97 series is a direct acting 2-way normally closed solenoid valve designed to handle cryogenic fluids and gases down to -320°F . This series employs Teflon plunger guides which help the valve to operate in the extremely high friction environment that is typical with cryogenic applications. This feature also yields quieter operation and long life. The springloaded disc and direct acting poppet design ensures proper sealing and reliable shifting in high on/off cycling

APPLICATIONS

The SV97 series is a rugged construction suitable for a variety of cryogenic applications such as the following:

- Food processing/preserving
- Backup system for biologic freezers
- Environmental chambers
- Metal treatment
- Gas chromatography
- Fogging machines
- Cryogenic surgery equipment

FEATURES

- Proprietary seat/seal design for cryogenic fluids to -320°F
- Direct acting design with no minimum operating pressure
- Quiet operation with bubble-tight shutoff
- Welded construction eliminates external leakage
- Pressure rating up to 1000 PSI
- Mountable in any position



VALCOR SV97 SPECIFICATIONS

Construction

Valve Parts in Contact with Fluid

Body	SS
Seal Disc	Teflon
Plunger Tube	303 SS
Plunger	430F SS
Plunger Stop	430F SS
Spring	303 SS
Rider Rings	Teflon
Shading Coil	Copper

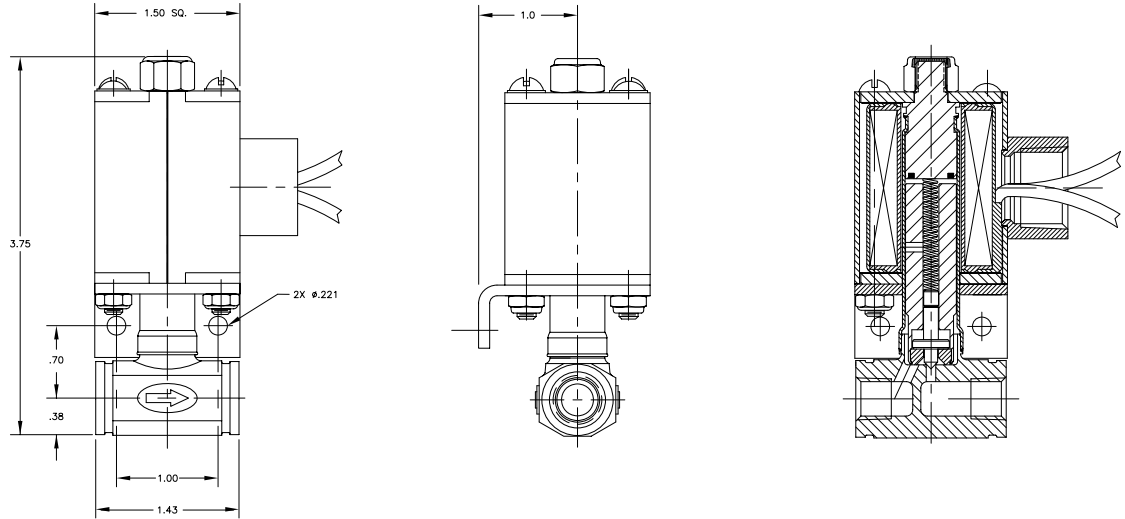

Electrical

Standard voltages	115/60 AC & 24/VDC. Consult factory for other voltages
Standard coil housing	General purpose with 1/2" NPT conduit Explosion proof and grommeted pigtails are available. Consult factory. Replace 1st "C" in part number with "ER" for explosion proof Replace 1st "C" in part number with "G" for grommeted pigtails. Example: SV97ER88HC8-4 for explosion proof solenoid Encapsulated with Din terminals for 18 mm (43650A) connector is available. Consult factory for part numbers

Specifications

Port Size (NPT)	Orifice Size (ins.)	C _v	Max Pressure (PSI)				Model Number		Wattage	
			AC		DC		Normally Closed		115/60 Hz	24/DC
			Gas	Liquid	Gas	Liquid	AC	DC		
2-way Normally Closed										
1/4	5/64	0.04	1000	1000	1000	1000	SV97C88HC1B	SV97C84C1B	14	21
1/4	3/32	0.20	775	675	750	650	SV97C88HC2B	SV97C84C2B	14	21
1/4	1/8	0.40	550	300	400	275	SV97C88HC3B	SV97C84C3B	14	21
1/4	5/32	0.50	275	175	200	165	SV97C88HC4B	SV97C84C4B	14	21
1/4	3/16	0.60	175	125	125	100	SV97C88HC5B	SV97C84C5B	14	21
1/4	1/4	0.80	75	75	50	45	SV97C88HC6B	SV97C84C6B	14	21