

SV33 & SV43 Series

Compact 2-Way Direct Acting Solenoid Valves

SV330, SV331 • Normally Closed

SV430, SV431 • Normally Open

These compact, 2-way direct acting solenoid valves are available in normally closed and normally open operating modes. They range from 1/8" to 3/8" NPT connection with orifice sizes from 3/64" to 3/8". These sturdy compact construction valves are designed to handle a variety of fluids with an operating pressure range of 0 PSI up to 1050 PSI. A wide selection of body materials, sealing/seat material, housings and voltages are available. For special applications, please contact your Valcor customer service representative.

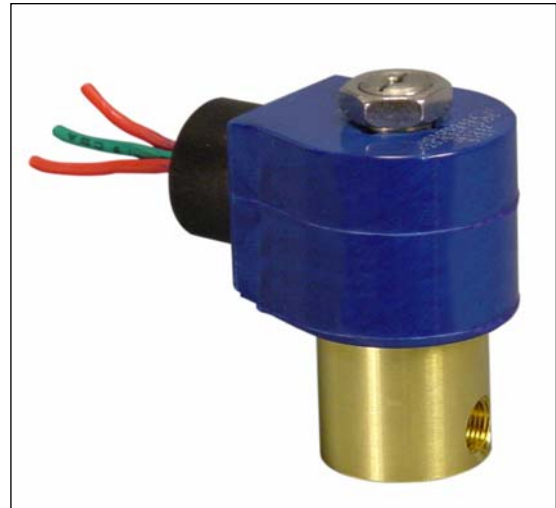

Specifications

Operating Mode	Normally Closed	Open when energized, closed when de-energized.	
	Normally Open	Closed when energized, open when de-energized.	
Pipe Size (in.)	1/8 • 1/4 • 3/8		
Orifice Size (in.)	3/64 to 3/8		
Body	Brass, 303 Stainless Steel		
Sealing/Seat	Buna N, Ethylene Propylene, Viton, Teflon		
Housing	Standard	Watertight NEMA 4	
	Options	Explosion proof NEMA 7, Open Frame, Junction box	
Available Voltages	AC24V 60Hz AC110V 50Hz AC120V 60Hz AC220V 50Hz AC240V 60Hz	12/DC 24/DC	
Voltage Tolerance	+10% to -15% of applicable voltage		
Coil	Class F and H		
Lead Length	24 inch		
Temperature Ratings	Ambient Temp.-40°F to 150°F max. with Class F Coil; 175°F max. with Class H Coil.		
	Fluid Temp. See the "HOW TO ORDER" Table.		
Mounting position	Mounts in any position (Best position is solenoid upright and vertical)		
Agency Listings	Consult factory		
Options	Manual Override, Neon Lamp, Surge Suppressor, Mounting Bracket		

*Consult the factory for specifications other than those listed above.



Valve Selection Sheet

Pipe Size (in.) NPT	Orifice (in.)	Cv	Operating Pressure Differential				Max. Fluid Temp. °F	Housing	Power Consumption (W)		Coil Insulation	Voltage 60 HZ	Model Code			
			Max. PSI						AC	DC			AC	DC	Brass	303 S.S.
			Air/Gas, Water, Lt. Oil		Steam											
			Min PSI	AC	DC	AC			DC							

Normally Closed

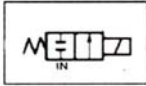

De-energized

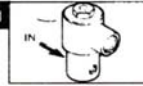

Energized



1/8	3/64	0.05	0	770	420	-	-	200	G	8	9	F	120	SV331GF02V8AC3	SV331GF02V2AC3
	1/16	0.10	0	560	185	-	-	200	G	8	9	F	120	SV331GF02V8AC5	SV331GF02V2AC5
	3/32	0.21	0	300	130	-	-	200	G	8	9	F	120	SV331GF02V8AC9	SV331GF02V2AC9
	1/8	0.32	0	155	60	-	-	200	G	8	9	F	120	SV331GF02V8AD5	SV331GF02V2AD5
	1/8	0.32	0	-	-	100	60	298	G	8	9	H	120	SV331GH02T8AD5	SV331GH02T2AD5
	5/32	0.43	0	105	35	-	-	200	G	8	9	F	120	SV331GF02V8AD7	SV331GF02V2AD7
	3/16	0.49	0	75	20	-	-	200	G	8	9	F	120	SV331GF02V8AE1	SV331GF02V2AE1
1/4	1/16	0.10	0	560	185	-	-	200	G	8	9	F	120	SV331GF02V8BC5	SV331GF02V3BC5
	3/32	0.21	0	300	130	-	-	200	G	8	9	F	120	SV331GF02V8BC9	SV331GF02V3BC9
	5/32	0.43	0	105	35	-	-	200	G	8	9	F	120	SV331GF02V8BD7	SV331GF02V3BD7
1/4	3/64	0.05	0	1050	1000	-	-	200	G	10	10	F	120	SV330GF02V8BC3	SV330GF02V3BC3
	1/16	0.10	0	700	300	-	-	200	G	10	10	F	120	SV330GF02V8BC5	SV330GF02V3BC5
	5/64	0.14	0	500	240	-	-	200	G	10	10	F	120	SV330GF02V8BC7	SV330GF02V3BC7
	3/32	0.21	0	400	200	-	-	200	G	10	10	F	120	SV330GF02V8BC9	SV330GF02V3BC9
	1/8	0.36	0	200	140	-	-	200	G	10	10	F	120	SV330GF02V8BD5	SV330GF02V3BD5
	5/32	0.44	0	150	100	-	-	200	G	10	10	F	120	SV330GF02V8BD7	SV330GF02V3BD7
	3/16	0.65	0	100	70	-	-	200	G	10	10	F	120	SV330GF02V8BE1	SV330GF02V3BE1
	3/16	0.65	0	-	-	100	70	298	G	10	10	H	120	SV330GH02T8BE1	SV330GH02T3BE1
1/4	0.85	0	50	20	-	-	200	G	10	10	F	120	---	SV330GF02V3BE7	
3/8	1/8	0.36	0	200	140	-	-	200	G	10	10	F	120	SV330GF02V9CD5	SV330GF02V3CD5
	3/16	0.65	0	100	70	-	-	200	G	10	10	F	120	SV330GF02V9CE1	SV330GF02V3CE1
	9/32	1.00	0	35	15	-	-	200	G	10	10	F	120	SV330GF02V9CF1	SV330GF02V3CF1
	3/8	1.70	0	20	5	-	-	200	G	10	10	F	120	SV330GF02V9CF5	SV330GF02V3CF5

Normally Open

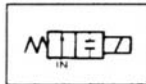

De-energized



Energized



1/8	3/64	0.05	0	350	350	-	-	200	G	8	9	F	120	SV431GF02V8AC3	SV431GF02V2AC3
	1/16	0.10	0	200	200	-	-	200	G	8	9	F	120	SV431GF02V8AC5	SV431GF02V2AC5
	3/32	0.20	0	105	105	-	-	200	G	8	9	F	120	SV431GF02V8AC9	SV431GF02V2AC9
	1/8	0.30	0	60	60	-	-	200	G	8	9	F	120	SV431GF02V8AD5	SV431GF02V2AD5
1/4	3/16	0.65	0	-	-	30	-	298	G	8	9	H	120	SV431GH02T8BE1	SV431GH02T3BE1
	3/64	0.05	0	600	600	-	-	200	G	11	10	F	120	SV430GF02V8BC3	SV430GF02V3BC3
	1/16	0.10	0	325	325	-	-	200	G	11	10	F	120	SV430GF02V8BC5	SV430GF02V3BC5
	3/32	0.20	0	150	150	-	-	200	G	11	10	F	120	SV430GF02V8BC9	SV430GF02V3BC9
	1/8	0.30	0	100	100	-	-	200	G	11	10	F	120	SV430GF02V8BD5	SV430GF02V3BD5
	3/16	0.65	0	40	40	-	-	200	G	11	10	F	120	SV430GF02V8BE1	SV430GF02V3BE1

For more information, call Valcor Scientific at 973-467-8000 or visit www.valcor.com

Model Code

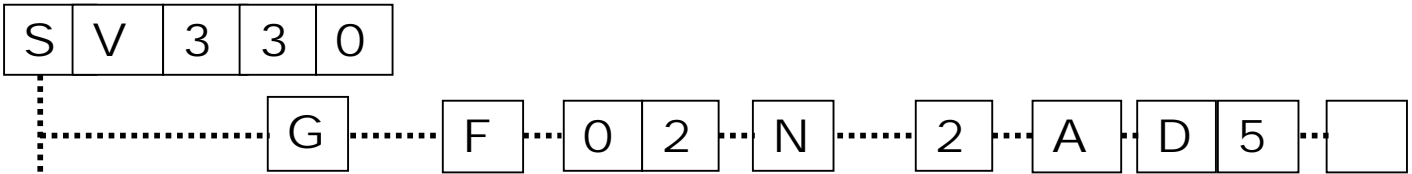

1-2-3-4-5		6	7	8-9		10	11	12	13-14		15						
Series (see note2)	Operating Mode	Housing		Coil Insulation		Applicable Voltage		Seat Material	Body Code	Pipe Connection	Orifice Size	Option					
SV330	Normally Closed	A=	Conduit	F=	Class F	02=	120V/60HZ 110V/50HZ	N=	Buna N	2=	S.S.(1/8" NPT)	A=	1/8	C3=	3/64	M=	Manual Override
SV430	Normally Open	P=	Open Frame	H=	Class H	04=	220V/60HZ 220V/50HZ	V=	Viton	3=	S.S.(1/4" & 3/8" NPT)	B=	1/4	C5=	1/16	K=	Mounting Bracket
SV331	Normally Closed	B=	Grommet			01=	24V/60HZ	C=	Ethylene Propylene	8=	Brass (1/8" & 1/4" NPT)	C=	3/8	C7=	5/64		
SV431	Normally Open	X=	Explosion Proof NEMA 7			15=	12V DC	T=	Teflon	9=	Brass (3/8" NPT)			C9=	3/32		
		S=	Junction Box			16=	24V DC	J=	Buna N*					D5=	1/8		
		G=	Watertight NEMA 4					L=	Viton*					D7=	5/32		
		Y=	DIN					E=	Ethylene Propylene*					E1=	3/16		
														E7=	1/4		
														F1=	9/32		
														F5=	3/8		

Coil Data

Note: 1)* Standard shading coil material is copper. "J*", "L*", "E*" has silver shading coil.
 2) Coil wattage for SV330 is 10W for AC & DC, for SV331 8W on AC and 9 watts on DC for SV430 11W on AC and 10W on DC, for SV431 8W on AC and 9W on DC.

Model		SV330		SV430		SV331		SV431	
Frequency (HZ)		50	60	50	60	50	60	50	60
Power (VA)	Inrush	37	30	43	37	26	22	35	30
	Holding	18	13	23	16	14	11	19	14
Power Consumption (W)	AC	10		11		8		8	
	DC	10				9			

Construction / Operation

Normally Closed

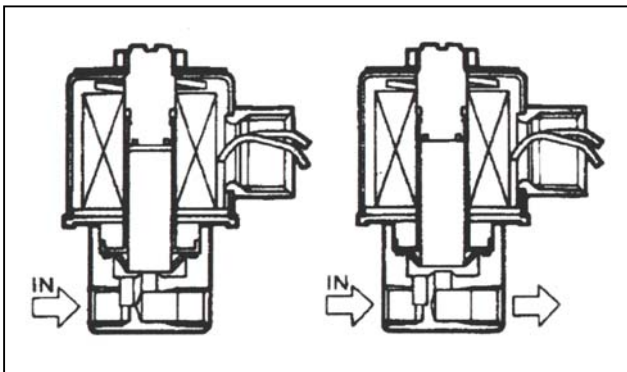

Normally Open

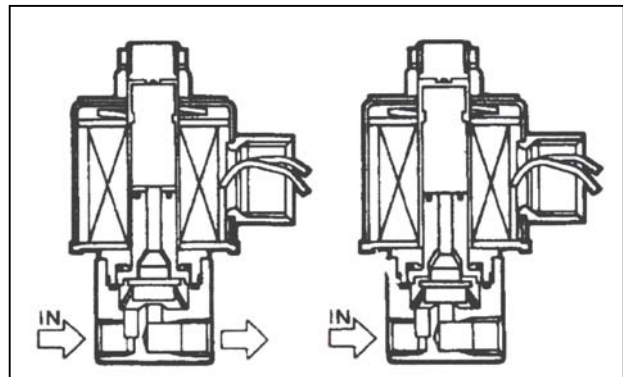

For more information, call Valcor Scientific at 973-467-8000 or visit www.valcor.com

External Dimensions

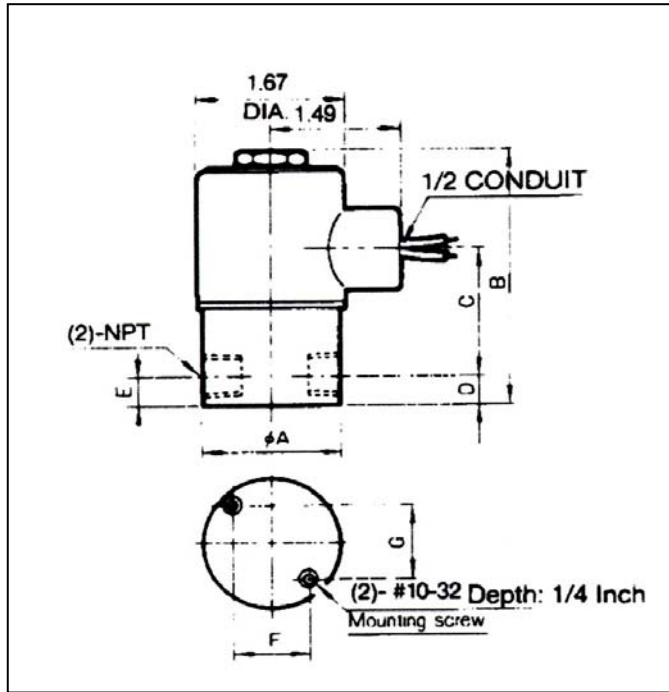

Body Code	Pipe Conn. (in.)	Model	A	B	C	D	E	F	G	Weight (LB)
2,3,8	1/8	SV330	1.22	3.10	1.71	0.29	0.29	0.61	0.73	0.90
		SV430		3.43						
		SV331		2.78	1.63					0.90
		SV431		2.94						
	1/4	SV330	1.63	3.14	1.71	0.37	0.37	0.91	0.91	1.10
		SV430		3.51						
SV330		3.63		2.12	0.45					0.98
9	1/8	SV331	1.63	2.90	1.63	0.37	0.37	---	---	0.09
		SV431		3.06						
	SV330	3.14		1.71						
	SV430	3.51								
	3/8	SV330		1.89	3.30					1.43

Units: inch

VALCOR ENGINEERING CORPORATION®

2 Lawrence Road Springfield, New Jersey 07081 USA 973-467-8400

Fax: 973-467-9592 Internet: <http://www.valcor.com>



Scientific Business Unit